



INPUT SHAFTS

NUT OR SNAP RING		SEE TABLE Z1
COVER		SEE TABLE Z3
SEAL		SEE TABLE Z2

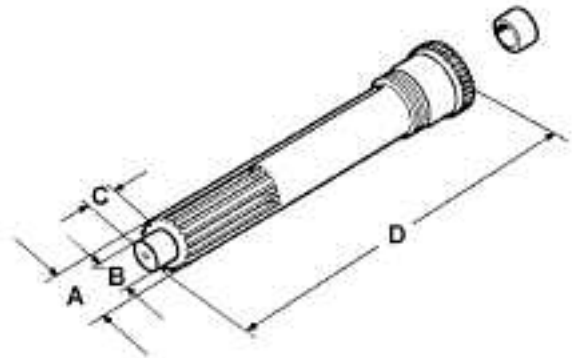

TABLE INPUT SHAFTS FOR 6 SPEEDS

MODELS	INPUT KIT PART NO. Only Shaft	PART NO. W/BUSH	TYPE	A Inches	B Inches	C Inches	D Inches	NUT/SR	COVER	SEAL
RT-906	14660	S-1130	PUSH	1.75	1.18	0.81	12.12	C	F	---
T-1056	14661	S-1131	PULL	1.75	1.18	0.81	12.12	D	G	---
T-1056 A	14995	S-1132	PUSH	2.00	1.18	0.81	12.12	C	I	---
T11605	15110	S-1133	PULL	2.00	1.18	0.81	12.12	D	J	---
	15112	S-1134	PUSH	2.00	1.18	0.81	12.12	E	K	D
	16983	S-1343	PULL	1.75	1.18	0.81	12.12	F	H	B
	16984	S-1344	PULL	2.00	1.18	0.81	12.12	F	H	C
	20530	S-1496	PUSH	1.75	1.18	0.81	12.12	F	L	---
	20531	S-1497	PULL	1.75	1.18	0.81	12.12	F	M	---
	23569	S-1661	PULL	2.00	1.18	0.81	12.12	F	N	---
	23570	S-1662	PUSH	2.00	1.18	0.81	12.12	F	O	---

TABLE INPUT SHAFTS FOR 7 SPEEDS

MODELS	INPUT KIT PART NO. Only Shaft	PART NO. W/BUSH	TYPE	A Inches	B Inches	C Inches	D Inches	NUT/SR	COVER	SEAL
T-8607	20530	S-1496	PUSH	1.75	1.18	0.81	12.12	F	L	---
T-8607 B	20531	S-1497	PULL	1.75	1.18	0.81	12.12	F	M	---
	23569	S-1661	PULL	2.00	1.18	0.81	12.12	F	N	---
	23570	S-1662	PUSH	2.00	1.18	0.81	12.12	F	O	---
<hr/>										
T-11607	14660	S-1130	PUSH	1.75	1.18	0.81	12.12	C	F	---
T-11607 A	14661	S-1131	PULL	1.75	1.18	0.81	12.12	D	G	---
T-11607 B	14995	S-1132	PUSH	2.00	1.18	0.81	12.12	C	I	---
	15110	S-1133	PULL	2.00	1.18	0.81	12.12	D	J	---
	15112	S-1134	PUSH	2.00	1.18	0.81	12.12	E	K	D
	16983	S-1343	PULL	1.75	1.18	0.81	12.12	F	H	B
	16984	S-1344	PULL	2.00	1.18	0.81	12.12	F	H	C
	20530	S-1496	PUSH	1.75	1.18	0.81	12.12	F	L	---
	20531	S-1497	PULL	1.75	1.18	0.81	12.12	F	M	---
	23569	S-1661	PULL	2.00	1.18	0.81	12.12	F	N	---
	23570	S-1662	PUSH	2.00	1.18	0.81	12.12	F	O	---
<hr/>										
T-14607 A	23569	S-1661	PULL	2.00	1.18	0.81	12.12	F	N	---
T/TX-14607 B	23570	S-1662	PUSH	2.00	1.18	0.81	12.12	F	O	---

PARTS LISTED IN THIS CATALOG ARE NOT NECESSARILY MANUFACTURED BY THE ORIGINAL EQUIPMENT MANUFACTURER AND ANY REFERENCE TO THE TRADEMARKS OR PART NUMBERS OF OTHERS ARE FOR CROSS REFERENCE INFORMATIONAL PURPOSES ONLY. THE TRADEMARKS OF OTHERS REFERRED TO HEREIN ARE OWNED BY THEIR RESPECTIVE COMPANIES AND ARE NOT AFFILIATED IN ANY WAY WITH MIDWEST TRUCK & AUTO PARTS, INC.® MOTIVE GEAR® AND WORLD AMERICAN® ARE THE REGISTERED TRADEMARKS OF MIDWEST TRUCK & AUTO PARTS, INC.® USE OF THE ® IN CONNECTION WITH A MARK OF MIDWEST TRUCK & AUTO PARTS, INC.® INDICATES THAT THE MARK IS REGISTERED IN AT LEAST THE UNITED STATES. NO REPRESENTATION IS MADE WITH RESPECT TO THE SOURCE OF MANUFACTURE OF ANY PARTICULAR PART. © 2005, MIDWEST TRUCK & AUTO PARTS, INC.® ALL RIGHTS RESERVED.

INPUT SHAFTS

NUT OR SNAP RING  **SEE TABLE Z1**

COVER  **SEE TABLE Z3**

SEAL  **SEE TABLE Z2**

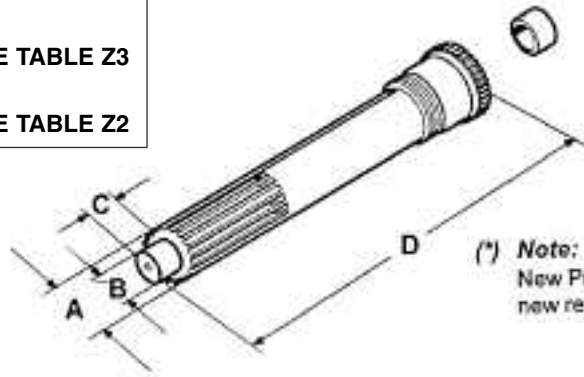

(*) **Note:**
New Production with
new revised spline.



TABLE INPUT SHAFTS FOR 8 SPEEDS

MODELS	INPUT KIT PART NO. Only Shaft	PART NO. W/BUSH	TYPE	A Inches	B Inches	C Inches	D Inches	NUT/ SR	COVER	SEAL
RTO-1157DL	15110	S-1133	PULL	2.00	1.18	0.81	12.12	D	J	---
	16984	S-1344	PULL	2.00	1.18	0.81	12.12	F	H	C
	23569	S-1661	PULL	2.00	1.18	0.81	12.12	F	N	---
RT-9508	14660	S-1130	PUSH	1.75	1.18	0.81	12.12	C	F	---
RTO-11607L	14661	S-1131	PULL	1.75	1.18	0.81	12.12	D	G	---
	14995	S-1132	PUSH	2.00	1.18	0.81	12.12	C	I	---
	15110	S-1133	PULL	2.00	1.18	0.81	12.12	D	J	---
	15112	S-1134	PUSH	2.00	1.18	0.81	12.12	E	K	D
	16983	S-1343	PULL	1.75	1.18	0.81	12.12	F	H	B
	16984	S-1344	PULL	2.00	1.18	0.81	12.12	F	H	C
	20530	S-1496	PUSH	1.75	1.18	0.81	12.12	F	L	---
	20531	S-1497	PULL	1.75	1.18	0.81	12.12	F	M	---
	23569	S-1661	PULL	2.00	1.18	0.81	12.12	F	N	---
	23570	S-1662	PUSH	2.00	1.18	0.81	12.12	F	O	---
RT-11608	16465	S-1128	PULL	2.00	1.18	0.81	11.94	D	J	---
	16466	S-1129	PUSH	2.00	1.18	0.81	11.94	C	I	---
	18837	S-1409	PULL	2.00	1.18	0.81	11.94	F	H	C
	19316	S-1406	PULL	1.75	1.18	0.81	11.94	D	G	---
	19714		PUSH	1.75	1.18	0.81	11.94	C	F	---
	19716		PUSH	2.00	1.18	0.81	11.94	E	K	D
	20532	S-1498	PUSH	1.75	1.18	0.81	11.94	F	L	---
	20538	S-1504	PULL	1.75	1.18	0.81	11.94	F	M	---
	23566	S-1659*	PULL	2.00	1.18	0.81	11.94	F	N	---
	23567	S-1660	PUSH	2.00	1.18	0.81	11.94	F	O	---
	14608 SERIES	16465	S-1128	PULL	2.00	1.18	0.81	11.94	D	J
16466		S-1129	PUSH	2.00	1.18	0.81	11.94	C	I	---
18837		S-1409	PULL	2.00	1.18	0.81	11.94	F	H	C
19716			PUSH	2.00	1.18	0.81	11.94	E	K	D
23566		S-1659*	PULL	2.00	1.18	0.81	11.94	F	N	---
23567		S-1660	PUSH	2.00	1.18	0.81	11.94	F	O	---

PARTS LISTED IN THIS CATALOG ARE NOT NECESSARILY MANUFACTURED BY THE ORIGINAL EQUIPMENT MANUFACTURER AND ANY REFERENCE TO THE TRADEMARKS OR PART NUMBERS OF OTHERS ARE FOR CROSS REFERENCE INFORMATIONAL PURPOSES ONLY. THE TRADEMARKS OF OTHERS REFERRED TO HEREIN ARE OWNED BY THEIR RESPECTIVE COMPANIES AND ARE NOT AFFILIATED IN ANY WAY WITH MIDWEST TRUCK & AUTO PARTS, INC.® MOTIVE GEAR® AND WORLD AMERICAN® ARE THE REGISTERED TRADEMARKS OF MIDWEST TRUCK & AUTO PARTS, INC.® USE OF THE ® IN CONNECTION WITH A MARK OF MIDWEST TRUCK & AUTO PARTS, INC.® INDICATES THAT THE MARK IS REGISTERED IN AT LEAST THE UNITED STATES. NO REPRESENTATION IS MADE WITH RESPECT TO THE SOURCE OF MANUFACTURE OF ANY PARTICULAR PART. © 2005, MIDWEST TRUCK & AUTO PARTS, INC.® ALL RIGHTS RESERVED.

INPUT SHAFTS

NUT OR SNAP RING ☞ SEE TABLE Z1

COVER ☞ SEE TABLE Z3

SEAL ☞ SEE TABLE Z2

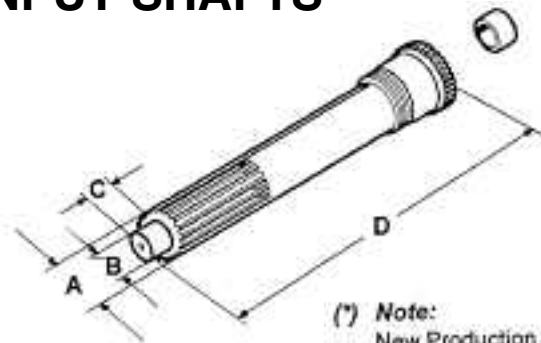

(*) Note:
New Production with
new revised spline.

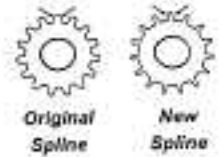

TABLE INPUT SHAFTS FOR 9 SPEEDS

MODELS	INPUT KIT		TYPE	A Inches	B Inches	C Inches	D Inches	NUT/ Inches	SR	COVER	SEAL
	PART NO. Only Shaft	PART NO. W/BUSH									
RT-909A	14660	S-1130	PUSH	1.75	1.18	0.81	12.12	C	F	---	
RTO-909 A/B	14661	S-1131	PULL	1.75	1.18	0.81	12.12	D	G	---	
RT-9509 A/C	14995	S-1132	PUSH	2.00	1.18	0.81	12.12	C	I	---	
RTO-9509 A/B	15110	S-1133	PULL	2.00	1.18	0.81	12.12	D	J	---	
	15112	S-1134	PUSH	2.00	1.18	0.81	12.12	E	K	D	
	16983	S-1343	PULL	1.75	1.18	0.81	12.12	F	H	B	
	16984	S-1344	PULL	2.00	1.18	0.81	12.12	F	H	C	
	20530	S-1496	PUSH	1.75	1.18	0.81	12.12	F	L	---	
	20531	S-1497	PULL	1.75	1.18	0.81	12.12	F	M	---	
	23569	S-1661	PULL	2.00	1.18	0.81	12.12	F	N	---	
	23570	S-1662	PUSH	2.00	1.18	0.81	12.12	F	O	---	
	F88983		PUSH	1.75	0.98	1.50	14.25	C	R	---	
<hr/>											
RT-11509	16465	S-1128	PULL	2.00	1.18	0.81	11.94	D	J	---	
RTO/RTX-11509	18837	S-1409	PULL	2.00	1.18	0.81	11.94	F	H	C	
	23566	S-1659*	PULL	2.00	1.18	0.81	11.94	F	N	---	
<hr/>											
RT-12509	16465	S-1128	PULL	2.00	1.18	0.81	11.94	D	J	---	
RTO/RTX-12509	16466	S-1129	PUSH	2.00	1.18	0.81	11.94	C	I	---	
	18837	S-1409	PULL	2.00	1.18	0.81	11.94	F	H	C	
	23566	S-1659*	PULL	2.00	1.18	0.81	11.94	F	N	---	
	23567	S-1660	PUSH	2.00	1.18	0.81	11.94	F	O	---	
<hr/>											
RT/RTX-6609	U66002										
RT/RTX-7609	F99715		PUSH								
	F99779										
	F99869		PULL								
	U66002										
<hr/>											
RT-8609	20787	A-5021	PULL	2.00	1.18	0.81	12.50	B	D	---	
	20788	A-5022	PULL	1.75	1.18	0.81	12.50	B	D	---	
	21001	A-5083	PULL	1.75	1.18	0.81	12.50	B	D	---	
<hr/>											
RT-8608L	20532	S-1498	PUSH	1.75	1.18	0.81	11.94	F	L	---	
	20538	S-1504	PULL	1.75	1.18	0.81	11.94	F	M	---	
	23566	S-1659*	PULL	2.00	1.18	0.81	11.94	F	N	---	
	23567	S-1660	PUSH	2.00	1.18	0.81	11.94	F	O	---	
RT/RTO-11609	16465	S-1128	PULL	2.00	1.18	0.81	11.94	D	J	---	
RTX-11609	16466	S-1129	PUSH	2.00	1.18	0.81	11.94	C	I	---	
RT/RTO-12609	F96031	T20085		2.00	1.18	0.81	11.94				
RTX-12609	18837	S-1409	PULL	2.00	1.18	0.81	11.94	F	H	C	

PARTS LISTED IN THIS CATALOG ARE NOT NECESSARILY MANUFACTURED BY THE ORIGINAL EQUIPMENT MANUFACTURER AND ANY REFERENCE TO THE TRADEMARKS OR PART NUMBERS OF OTHERS ARE FOR CROSS REFERENCE INFORMATIONAL PURPOSES ONLY. THE TRADEMARKS OF OTHERS REFERRED TO HEREIN ARE OWNED BY THEIR RESPECTIVE COMPANIES AND ARE NOT AFFILIATED IN ANY WAY WITH MIDWEST TRUCK & AUTO PARTS, INC.® MOTIVE GEAR® AND WORLD AMERICAN® ARE THE REGISTERED TRADEMARKS OF MIDWEST TRUCK & AUTO PARTS, INC.® USE OF THE ® IN CONNECTION WITH A MARK OF MIDWEST TRUCK & AUTO PARTS, INC.® INDICATES THAT THE MARK IS REGISTERED IN AT LEAST THE UNITED STATES. NO REPRESENTATION IS MADE WITH RESPECT TO THE SOURCE OF MANUFACTURE OF ANY PARTICULAR PART. © 2005, MIDWEST TRUCK & AUTO PARTS, INC.® ALL RIGHTS RESERVED.

INPUT SHAFTS

NUT OR SNAP RING  SEE TABLE Z1

COVER  SEE TABLE Z3

SEAL  SEE TABLE Z2

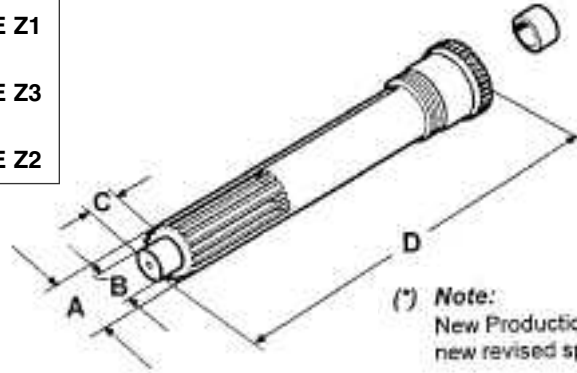

(*) Note:
New Production with
new revised spline.

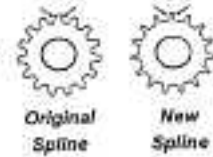

TABLE INPUT SHAFTS FOR 9 SPEEDS (Cont'd)

MODELS	INPUT KIT PART NO. Only Shaft	PART NO. W/BUSH	TYPE	A Inches	B Inches	C Inches	D Inches	NUT/ SR	COVER	SEAL
	19316	S-1406	PULL	1.75	1.18	0.81	11.94	D	G	---
	19714		PUSH	1.75	1.18	0.81	11.94	C	F	---
	19716		PUSH	2.00	1.18	0.81	11.94	E	K	D
	20532	S-1498	PUSH	1.75	1.18	0.81	11.94	F	L	---
	20538	S-1504	PULL	1.75	1.18	0.81	11.94	F	M	---
	23566	S-1659*	PULL	2.00	1.18	0.81	11.94	F	N	---
	23567	S-1660	PUSH	2.00	1.18	0.81	11.94	F	O	---
<hr/>										
RT/RTX-13609	23566	S-1659*	PULL	2.00	1.18	0.81	11.94	F	N	---
	23567	S-1660	PUSH	2.00	1.18	0.81	11.94	F	O	---
<hr/>										
RT/RTO-14609	16465	S-1128	PULL	2.00	1.18	0.81	11.94	D	J	---
RTX-14609	16466	S-1129	PUSH	2.00	1.18	0.81	11.94	C	I	---
	18837	S-1409	PULL	2.00	1.18	0.81	11.94	F	H	C
	23566	S-1659*	PULL	2.00	1.18	0.81	11.94	F	N	---
	23567	S-1660	PUSH	2.00	1.18	0.81	11.94	F	O	---
<hr/>										
RT/RTO-11709	23566	S-1659*	PULL	2.00	1.18	0.81	11.94	F	N	---
RTX-11709	23567	S-1660	PUSH	2.00	1.18	0.81	11.94	F	O	---
<hr/>										
RT/RTO-12709	23566	S-1659*	PULL	2.00	1.18	0.81	11.94	F	N	---
RTX-12709	23567	S-1660	PUSH	2.00	1.18	0.81	11.94	F	O	---
<hr/>										
RT/RTO-13709	23566	S-1659*	PULL	2.00	1.18	0.81	11.94	F	N	---
RTX-13709	23567	S-1660	PUSH	2.00	1.18	0.81	11.94	F	O	---
<hr/>										
RT/RTO-14709	23566	S-1659*	PULL	2.00	1.18	0.81	11.94	F	N	---
RTX-14709	23567	S-1660	PUSH	2.00	1.18	0.81	11.94	F	O	---
<hr/>										
RT/RTO-16709	23566	S-1659*	PULL	2.00	1.18	0.81	11.94	F	N	---
RTX-16709	23567	S-1660	PUSH	2.00	1.18	0.81	11.94	F	O	---

PARTS LISTED IN THIS CATALOG ARE NOT NECESSARILY MANUFACTURED BY THE ORIGINAL EQUIPMENT MANUFACTURER AND ANY REFERENCE TO THE TRADEMARKS OR PART NUMBERS OF OTHERS ARE FOR CROSS REFERENCE INFORMATIONAL PURPOSES ONLY. THE TRADEMARKS OF OTHERS REFERRED TO HEREIN ARE OWNED BY THEIR RESPECTIVE COMPANIES AND ARE NOT AFFILIATED IN ANY WAY WITH MIDWEST TRUCK & AUTO PARTS, INC.® MOTIVE GEAR® AND WORLD AMERICAN® ARE THE REGISTERED TRADEMARKS OF MIDWEST TRUCK & AUTO PARTS, INC.® USE OF THE ® IN CONNECTION WITH A MARK OF MIDWEST TRUCK & AUTO PARTS, INC.® INDICATES THAT THE MARK IS REGISTERED IN AT LEAST THE UNITED STATES. NO REPRESENTATION IS MADE WITH RESPECT TO THE SOURCE OF MANUFACTURE OF ANY PARTICULAR PART. © 2005, MIDWEST TRUCK & AUTO PARTS, INC.® ALL RIGHTS RESERVED.

INPUT SHAFTS

NUT OR SNAP RING	☞	SEE TABLE Z1
COVER	☞	SEE TABLE Z3
SEAL	☞	SEE TABLE Z2

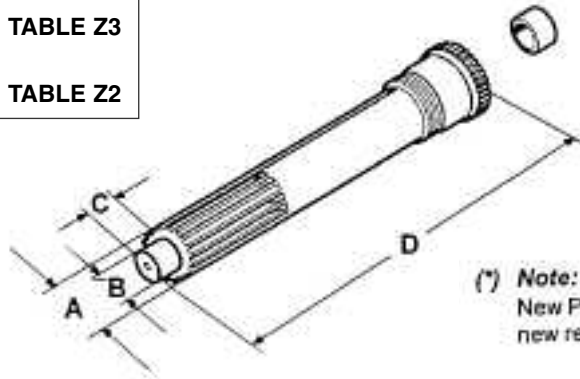

(*) Note:
New Production with
new revised spline.



TABLE INPUT SHAFTS FOR 9 SPEEDS (Cont'd)

MODELS	INPUT KIT PART NO. Only Shaft	PART NO. W/BUSH	TYPE	A Inches	B Inches	C Inches	D Inches	NUT/SR	COVER	SEAL
RTO-1157DLL	15110	S-1133	PULL	2.00	1.18	0.81	12.12	D	J	---
	16984	S-1344	PULL	2.00	1.18	0.81	12.12	F	H	C
<hr/>										
RTO-1157DLL	23569	S-1661	PULL	2.00	1.18	0.81	12.12	F	N	---
<hr/>										
RTO-11607LL	14660	S-1130	PUSH	1.75	1.18	0.81	12.12	C	F	---
	14661	S-1131	PULL	1.75	1.18	0.81	12.12	D	G	---
	14995	S-1132	PUSH	2.00	1.18	0.81	12.12	C	I	---
	15110	S-1133	PULL	2.00	1.18	0.81	12.12	D	J	---
	15112	S-1134	PUSH	2.00	1.18	0.81	12.12	E	K	D
	16983	S-1343	PULL	1.75	1.18	0.81	12.12	F	H	B
	16984	S-1344	PULL	2.00	1.18	0.81	12.12	F	H	C
	20530	S-1496	PUSH	1.75	1.18	0.81	12.12	F	L	---
	20531	S-1497	PULL	1.75	1.18	0.81	12.12	F	M	---
	23569	S-1661	PULL	2.00	1.18	0.81	12.12	F	N	---
23570	S-1662	PUSH	2.00	1.18	0.81	12.12	F	O	---	
<hr/>										
RTLO-11707LL	20530	S-1496	PUSH	1.75	1.18	0.81	12.12	F	L	---
	20531	S-1497	PULL	1.75	1.18	0.81	12.12	F	M	---
	23569	S-1661	PULL	2.00	1.18	0.81	12.12	F	N	---
	23570	S-1662	PUSH	2.00	1.18	0.81	12.12	F	O	---
<hr/>										
RTLO-13707LL	23569	S-1661	PULL	2.00	1.18	0.81	12.12	F	N	---

PARTS LISTED IN THIS CATALOG ARE NOT NECESSARILY MANUFACTURED BY THE ORIGINAL EQUIPMENT MANUFACTURER AND ANY REFERENCE TO THE TRADEMARKS OR PART NUMBERS OF OTHERS ARE FOR CROSS REFERENCE INFORMATIONAL PURPOSES ONLY. THE TRADEMARKS OF OTHERS REFERRED TO HEREIN ARE OWNED BY THEIR RESPECTIVE COMPANIES AND ARE NOT AFFILIATED IN ANY WAY WITH MIDWEST TRUCK & AUTO PARTS, INC.® MOTIVE GEAR® AND WORLD AMERICAN® ARE THE REGISTERED TRADEMARKS OF MIDWEST TRUCK & AUTO PARTS, INC.® USE OF THE ® IN CONNECTION WITH A MARK OF MIDWEST TRUCK & AUTO PARTS, INC.® INDICATES THAT THE MARK IS REGISTERED IN AT LEAST THE UNITED STATES. NO REPRESENTATION IS MADE WITH RESPECT TO THE SOURCE OF MANUFACTURE OF ANY PARTICULAR PART. © 2005, MIDWEST TRUCK & AUTO PARTS, INC.® ALL RIGHTS RESERVED.

INPUT SHAFTS

NUT OR SNAP RING  SEE TABLE Z1

COVER  SEE TABLE Z3

SEAL  SEE TABLE Z2

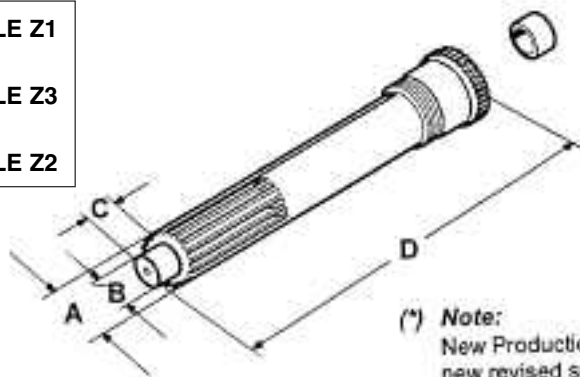

(*) Note:
New Production with
new revised spline.





TABLE INPUT SHAFTS FOR 10 SPEEDS

MODELS	INPUT KIT PART NO. Only Shaft	PART NO. W/BUSH	TYPE	A Inches	B Inches	C Inches	D Inches	NUT/ SR	COVER	SEAL
RT-RTO-610	18441	S-1250	PUSH	1.75	1.18	0.81	12.28	A	A	---
RT-RTO-6610	18442	S-1251	PUSH	1.75	0.98	0.81	12.28	A	A	---
	18443	S-1252	PUSH	1.50	0.98	0.81	11.42	A	B	---
	18444	S-1253	PULL	1.75	1.18	0.81	12.28	A	C	---
	18445	S-1254	PUSH	1.50	0.98	0.81	12.28	A	B	---
	18446	S-1255	PULL	1.75	0.98	0.81	12.28	A	C	---
<hr/>										
RT/RTO-910	15110	S-1133	PULL	2.00	1.18	0.81	12.12	D	J	---
	15112	S-1134	PUSH	2.00	1.18	0.81	12.12	E	K	D
	16983	S-1343	PULL	1.75	1.18	0.81	12.12	F	H	B
	16984	S-1344	PULL	2.00	1.18	0.81	12.12	F	H	C
	20530	S-1496	PUSH	1.75	1.18	0.81	12.12	F	L	---
	20531	S-1497	PULL	1.75	1.18	0.81	12.12	F	M	---
	23569	S-1661	PULL	2.00	1.18	0.81	12.12	F	N	---
	23570	S-1662	PUSH	2.00	1.18	0.81	12.12	F	O	---
<hr/>										
RT/RTO-1110	16465	S-1128	PULL	2.00	1.18	0.81	11.94	D	J	---
RTX-1110	18837	S-1409	PULL	2.00	1.18	0.81	11.94	F	H	C
	23566	S-1659*	PULL	2.00	1.18	0.81	11.94	F	N	---
<hr/>										
RT/RTO-11610	16465	S-1128	PULL	2.00	1.18	0.81	11.94	D	J	---
RTX-11610	16466	S-1129	PUSH	2.00	1.18	0.81	11.94	C	I	---
RT/RTO-12610	18837	S-1409	PULL	2.00	1.18	0.81	11.94	F	H	C
RTX-12610	19316	S-1406	PULL	1.75	1.18	0.81	11.94	D	G	---
RT/RTO-14610	19714		PUSH	1.75	1.18	0.81	11.94	C	F	---
RTX-14610	19716		PUSH	2.00	1.18	0.81	11.94	E	K	D
	20532	S-1498	PUSH	1.75	1.18	0.81	11.94	F	L	---
	20538	S-1504	PULL	1.75	1.18	0.81	11.94	F	M	---
	23566	S-1659*	PULL	2.00	1.18	0.81	11.94	F	N	---
	23567	S-1660	PUSH	2.00	1.18	0.81	11.94	F	O	---
<hr/>										
RT/RTO-12510	16465	S-1128	PULL	2.00	1.18	0.81	11.94	D	J	---
RTX-12510	16466	S-1129	PUSH	2.00	1.18	0.81	11.94	C	I	---
	18837	S-1409	PULL	2.00	1.18	0.81	11.94	F	H	C

PARTS LISTED IN THIS CATALOG ARE NOT NECESSARILY MANUFACTURED BY THE ORIGINAL EQUIPMENT MANUFACTURER AND ANY REFERENCE TO THE TRADEMARKS OR PART NUMBERS OF OTHERS ARE FOR CROSS REFERENCE INFORMATIONAL PURPOSES ONLY. THE TRADEMARKS OF OTHERS REFERRED TO HEREIN ARE OWNED BY THEIR RESPECTIVE COMPANIES AND ARE NOT AFFILIATED IN ANY WAY WITH MIDWEST TRUCK & AUTO PARTS, INC.® MOTIVE GEAR® AND WORLD AMERICAN® ARE THE REGISTERED TRADEMARKS OF MIDWEST TRUCK & AUTO PARTS, INC.® USE OF THE ® IN CONNECTION WITH A MARK OF MIDWEST TRUCK & AUTO PARTS, INC.® INDICATES THAT THE MARK IS REGISTERED IN AT LEAST THE UNITED STATES. NO REPRESENTATION IS MADE WITH RESPECT TO THE SOURCE OF MANUFACTURE OF ANY PARTICULAR PART. © 2005, MIDWEST TRUCK & AUTO PARTS, INC.® ALL RIGHTS RESERVED.

INPUT SHAFTS

NUT OR SNAP RING		SEE TABLE Z1
COVER		SEE TABLE Z3
SEAL		SEE TABLE Z2

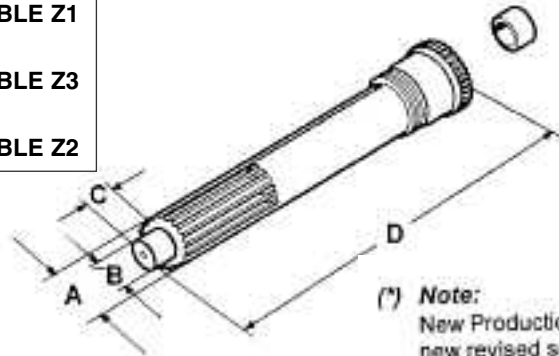

(*) Note:
New Production with
new revised spline.

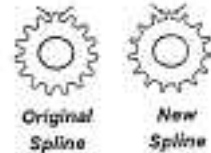

TABLE INPUT SHAFTS FOR 10 SPEEDS (Cont'd)

MODELS	INPUT KIT PART NO. Only Shaft	PART NO. W/BUSH	TYPE	A Inches	B Inches	C Inches	D Inches	NUT/ SR	COVER	SEAL
RT/RTO-12510	23566	S-1659*	PULL	2.00	1.18	0.81	11.94	F	N	---
RTX-12510	23567	S-1660	PUSH	2.00	1.18	0.81	11.94	F	O	---
<hr/>										
RT/RTX-11710	23566	S-1659*	PULL	2.00	1.18	0.81	11.94	F	N	---
	23567	S-1660	PUSH	2.00	1.18	0.81	11.94	F	O	---
<hr/>										
RT/RTX-12710	23566	S-1659*	PULL	2.00	1.18	0.81	11.94	F	N	---
	23567	S-1660	PUSH	2.00	1.18	0.81	11.94	F	O	---
<hr/>										
RT/RTX-13710	23566	S-1659*	PULL	2.00	1.18	0.81	11.94	F	N	---
	23567	S-1660	PUSH	2.00	1.18	0.81	11.94	F	O	---
<hr/>										
RT/RTX-14710	23566	S-1659*	PULL	2.00	1.18	0.81	11.94	F	N	---
	23567	S-1660	PUSH	2.00	1.18	0.81	11.94	F	O	---
<hr/>										
RT/RTX-15710	23566	S-1659*	PULL	2.00	1.18	0.81	11.94	F	N	---
	23567	S-1660	PUSH	2.00	1.18	0.81	11.94	F	O	---
<hr/>										
RT/RTX-16710	23566	S-1659	PULL	2.00	1.18	0.81	11.94	F	N	---
	23567	S-1660	PUSH	2.00	1.18	0.81	11.94	F	O	---
<hr/>										
RTLO-11610B	23566	S-1659*	PULL	2.00	1.18	0.81	11.94	F	N	---
	23567	S-1660	PUSH	2.00	1.18	0.81	11.94	F	O	---
<hr/>										
RTLO-12610B	23566	S-1659*	PULL	2.00	1.18	0.81	11.94	F	N	---
	23567	S-1660	PUSH	2.00	1.18	0.81	11.94	F	O	---
<hr/>										
RTLO-13610B	23566	S-1659*	PULL	2.00	1.18	0.81	11.94	F	N	---
	23567	S-1660	PUSH	2.00	1.18	0.81	11.94	F	O	---

PARTS LISTED IN THIS CATALOG ARE NOT NECESSARILY MANUFACTURED BY THE ORIGINAL EQUIPMENT MANUFACTURER AND ANY REFERENCE TO THE TRADEMARKS OR PART NUMBERS OF OTHERS ARE FOR CROSS REFERENCE INFORMATIONAL PURPOSES ONLY. THE TRADEMARKS OF OTHERS REFERRED TO HEREIN ARE OWNED BY THEIR RESPECTIVE COMPANIES AND ARE NOT AFFILIATED IN ANY WAY WITH MIDWEST TRUCK & AUTO PARTS, INC.® MOTIVE GEAR® AND WORLD AMERICAN® ARE THE REGISTERED TRADEMARKS OF MIDWEST TRUCK & AUTO PARTS, INC.® USE OF THE ® IN CONNECTION WITH A MARK OF MIDWEST TRUCK & AUTO PARTS, INC.® INDICATES THAT THE MARK IS REGISTERED IN AT LEAST THE UNITED STATES. NO REPRESENTATION IS MADE WITH RESPECT TO THE SOURCE OF MANUFACTURE OF ANY PARTICULAR PART. © 2005, MIDWEST TRUCK & AUTO PARTS, INC.® ALL RIGHTS RESERVED.

INPUT SHAFTS

NUT OR SNAP RING  SEE TABLE Z1
 COVER  SEE TABLE Z3
 SEAL  SEE TABLE Z2

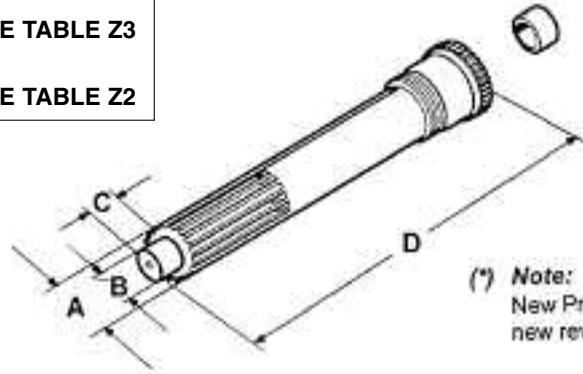

(*) Note:
New Production with
new revised spline.

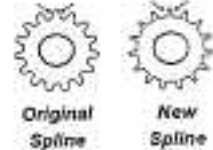

TABLE INPUT SHAFTS FOR 10 SPEEDS (Cont'd)

MODELS	INPUT KIT		TYPE	A Inches	B Inches	C Inches	D Inches	NUT/ SR	COVER	SEAL
	PART NO. Only Shaft	PART NO. W/BUSH								
RTLO-14610B	23566	S-1659*	PULL	2.00	1.18	0.81	11.94	F	N	---
	23567	S-1660	PUSH	2.00	1.18	0.81	11.94	F	O	---
RTLO-15610B	23566	S-1659*	PULL	2.00	1.18	0.81	11.94	F	N	---
	23567	S-1660	PUSH	2.00	1.18	0.81	11.94	F	O	---
RTLO-16610B	23566	S-1659*	PULL	2.00	1.18	0.81	11.94	F	N	---
	23567	S-1660	PUSH	2.00	1.18	0.81	11.94	F	O	---
RTO-958LL/LLB	14660	S-1130	PUSH	1.75	1.18	0.81	12.12	C	F	---
	14661	S-1131	PULL	1.75	1.18	0.81	12.12	D	G	---
	14995	S-1132	PUSH	2.00	1.18	0.81	12.12	C	I	---
	15110	S-1133	PULL	2.00	1.18	0.81	12.12	D	J	---
	15112	S-1134	PUSH	2.00	1.18	0.81	12.12	E	K	D
	16983	S-1343	PULL	1.75	1.18	0.81	12.12	F	H	B
	16984	S-1344	PULL	2.00	1.18	0.81	12.12	F	H	C
	20530	S-1496	PUSH	1.75	1.18	0.81	12.12	F	L	---
	20531	S-1497	PULL	1.75	1.18	0.81	12.12	F	M	---
	23569	S-1661	PULL	2.00	1.18	0.81	12.12	F	N	---
	23570	S-1662	PUSH	2.00	1.18	0.81	12.12	F	O	---
RTO-1258LL	16465	S-1128	PULL	2.00	1.18	0.81	11.94	D	J	---
	16466	S-1129	PUSH	2.00	1.18	0.81	11.94	C	I	---
	18837	S-1409	PULL	2.00	1.18	0.81	11.94	F	H	C
	23566	S-1659*	PULL	2.00	1.18	0.81	11.94	F	N	---
	23567	S-1660	PUSH	2.00	1.18	0.81	11.94	F	O	---
RTO-11608LL	16465	S-1128	PULL	2.00	1.18	0.81	11.94	D	J	---
	16466	S-1129	PUSH	2.00	1.18	0.81	11.94	C	I	---
	19316	S-1406	PULL	1.75	1.18	0.81	11.94	D	G	---
	19714		PUSH	1.75	1.18	0.81	11.94	C	F	---

PARTS LISTED IN THIS CATALOG ARE NOT NECESSARILY MANUFACTURED BY THE ORIGINAL EQUIPMENT MANUFACTURER AND ANY REFERENCE TO THE TRADEMARKS OR PART NUMBERS OF OTHERS ARE FOR CROSS REFERENCE INFORMATIONAL PURPOSES ONLY. THE TRADEMARKS OF OTHERS REFERRED TO HEREIN ARE OWNED BY THEIR RESPECTIVE COMPANIES AND ARE NOT AFFILIATED IN ANY WAY WITH MIDWEST TRUCK & AUTO PARTS, INC.® MOTIVE GEAR® AND WORLD AMERICAN® ARE THE REGISTERED TRADEMARKS OF MIDWEST TRUCK & AUTO PARTS, INC.® USE OF THE ® IN CONNECTION WITH A MARK OF MIDWEST TRUCK & AUTO PARTS, INC.® INDICATES THAT THE MARK IS REGISTERED IN AT LEAST THE UNITED STATES. NO REPRESENTATION IS MADE WITH RESPECT TO THE SOURCE OF MANUFACTURE OF ANY PARTICULAR PART. © 2005, MIDWEST TRUCK & AUTO PARTS, INC.® ALL RIGHTS RESERVED.

INPUT SHAFTS

NUT OR SNAP RING  SEE TABLE Z1
 COVER  SEE TABLE Z3
 SEAL  SEE TABLE Z2

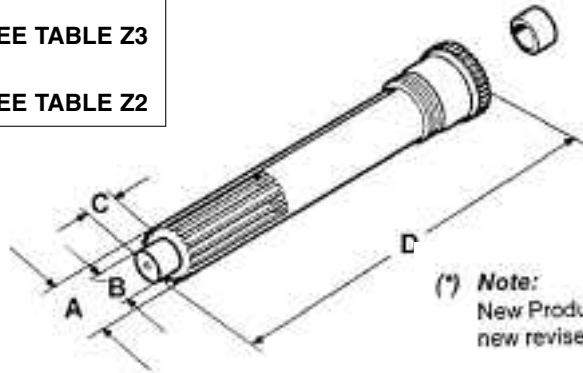

(*) Note:
New Production with
new revised spline.

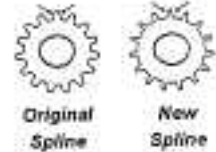

TABLE INPUT SHAFTS FOR 10 SPEEDS (Cont'd)

MODELS	INPUT KIT PART NO. Only Shaft	PART NO. W/BUSH	TYPE	A Inches	B Inches	C Inches	D Inches	NUT/SR	COVER	SEAL
	19716		PUSH	2.00	1.18	0.81	11.94	E	K	D
	18837	S-1409	PULL	2.00	1.18	0.81	11.94	F	H	C
RTO-11608LL	20532	S-1498	PUSH	1.75	1.18	0.81	11.94	F	L	---
	20538	S-1504	PULL	1.75	1.18	0.81	11.94	F	M	---
	23566	S-1659*	PULL	2.00	1.18	0.81	11.94	F	N	---
	23567	S-1660	PUSH	2.00	1.18	0.81	11.94	F	O	---
RTO-14608LL	16465	S-1128	PULL	2.00	1.18	0.81	11.94	D	J	---
	16466	S-1129	PUSH	2.00	1.18	0.81	11.94	C	I	---
	19716		PUSH	2.00	1.18	0.81	11.94	E	K	D
	23566	S-1659*	PULL	2.00	1.18	0.81	11.94	F	N	---
	23567	S-1660	PUSH	2.00	1.18	0.81	11.94	F	O	---
RTO-11708LL	20532	S-1498	PUSH	1.75	1.18	0.81	11.94	F	L	---
	20538	S-1504	PULL	1.75	1.18	0.81	11.94	F	M	---
	23566	S-1659*	PULL	2.00	1.18	0.81	11.94	F	N	---
	23567	S-1660	PUSH	2.00	1.18	0.81	11.94	F	O	---
8608LL Series	20787	A-5021	PULL	2.00	1.18	0.81	12.50	B	D	---
	20788	A-5022	PULL	1.75	1.18	0.81	12.50	B	D	---
	21001	A-5083	PULL	1.75	0.98	0.81	12.50	B	D	---

PARTS LISTED IN THIS CATALOG ARE NOT NECESSARILY MANUFACTURED BY THE ORIGINAL EQUIPMENT MANUFACTURER AND ANY REFERENCE TO THE TRADEMARKS OR PART NUMBERS OF OTHERS ARE FOR CROSS REFERENCE INFORMATIONAL PURPOSES ONLY. THE TRADEMARKS OF OTHERS REFERRED TO HEREIN ARE OWNED BY THEIR RESPECTIVE COMPANIES AND ARE NOT AFFILIATED IN ANY WAY WITH MIDWEST TRUCK & AUTO PARTS, INC.® MOTIVE GEAR® AND WORLD AMERICAN® ARE THE REGISTERED TRADEMARKS OF MIDWEST TRUCK & AUTO PARTS, INC.® USE OF THE ® IN CONNECTION WITH A MARK OF MIDWEST TRUCK & AUTO PARTS, INC.® INDICATES THAT THE MARK IS REGISTERED IN AT LEAST THE UNITED STATES. NO REPRESENTATION IS MADE WITH RESPECT TO THE SOURCE OF MANUFACTURE OF ANY PARTICULAR PART. © 2005, MIDWEST TRUCK & AUTO PARTS, INC.® ALL RIGHTS RESERVED.

INPUT SHAFTS

NUT OR SNAP RING  SEE TABLE Z1

COVER  SEE TABLE Z3

SEAL  SEE TABLE Z2

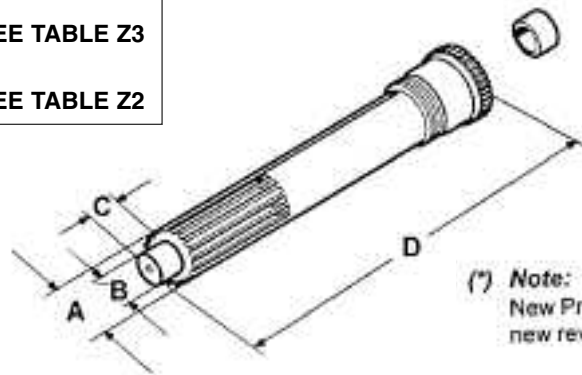

(*) Note:
New Production with
new revised spline.

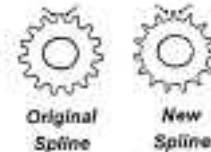

TABLE INPUT SHAFTS FOR 13 SPEEDS

MODELS	INPUT KIT		TYPE	A Inches	B Inches	C Inches	D Inches	NUT/ SR	COVER	SEAL
	PART NO. Only Shaft	PART NO. W/BUSH								
RT/RTO-613	18441	S-1250	PUSH	1.75	1.18	0.81	12.28	A	A	---
RT/RTO-6613	18442	S-1251	PUSH	1.75	0.98	0.81	12.28	A	A	---
	18443	S-1252	PUSH	1.50	0.98	0.81	11.42	A	B	---
	18444	S-1253	PULL	1.75	1.18	0.81	12.28	A	C	---
	18445	S-1254	PUSH	1.50	0.98	0.81	12.28	A	B	---
	18446	S-1255	PULL	1.75	0.98	0.81	12.28	A	C	---
<hr/>										
RTO/RTOO-913	14660	S-1130	PUSH	1.75	1.18	0.81	12.12	C	F	---
RT/RTO-9513	14661	S-1131	PULL	1.75	1.18	0.81	12.12	D	G	---
RTOO-9513	14995	S-1132	PUSH	2.00	1.18	0.81	12.12	C	I	---
	15110	S-1133	PULL	2.00	1.18	0.81	12.12	D	J	---
	15112	S-1134	PUSH	2.00	1.18	0.81	12.12	E	K	D
	16983	S-1343	PULL	1.75	1.18	0.81	12.12	F	H	B
	16984	S-1344	PULL	2.00	1.18	0.81	12.12	F	H	C
	20530	S-1496	PUSH	1.75	1.18	0.81	12.12	F	L	---
	20531	S-1497	PULL	1.75	1.18	0.81	12.12	F	M	---
	23569	S-1661	PULL	2.00	1.18	0.81	12.12	F	N	---
	23570	S-1662	PUSH	2.00	1.18	0.81	12.12	F	O	---
	F88983		PUSH	1.75	0.98	1.50	14.25	C	R	---
<hr/>										
RTO-1213	16465	S-1128	PULL	2.00	1.18	0.81	11.94	D	J	---
RT/RTO-12513	16466	S-1129	PUSH	2.00	1.18	0.81	11.94	C	I	---
	19716		PUSH	2.00	1.18	0.81	11.94	E	K	D
	18387	T20078	PUSH	1.75	0.98	1.23	12.92	C	U	A
	23566	S-1659	PULL	2.00	1.18	0.81	11.94	F	N	---
	23567	S-1660*	PUSH	2.00	1.18	0.81	11.94	F	O	---
<hr/>										
RT/RTO-11613	16465	S-1128	PULL	2.00	1.18	0.81	11.94	D	J	---
RTOO-11613	16466	S-1129	PUSH	2.00	1.18	0.81	11.94	C	I	---
	19316	S-1406	PULL	1.75	1.18	0.81	11.94	D	G	---
	19716		PUSH	2.00	1.18	0.81	11.94	E	K	D
	18387	T20078	PUSH	1.75	0.98	1.23	12.92	C	U	A

PARTS LISTED IN THIS CATALOG ARE NOT NECESSARILY MANUFACTURED BY THE ORIGINAL EQUIPMENT MANUFACTURER AND ANY REFERENCE TO THE TRADEMARKS OR PART NUMBERS OF OTHERS ARE FOR CROSS REFERENCE INFORMATIONAL PURPOSES ONLY. THE TRADEMARKS OF OTHERS REFERRED TO HEREIN ARE OWNED BY THEIR RESPECTIVE COMPANIES AND ARE NOT AFFILIATED IN ANY WAY WITH MIDWEST TRUCK & AUTO PARTS, INC.® MOTIVE GEAR® AND WORLD AMERICAN® ARE THE REGISTERED TRADEMARKS OF MIDWEST TRUCK & AUTO PARTS, INC.® USE OF THE ® IN CONNECTION WITH A MARK OF MIDWEST TRUCK & AUTO PARTS, INC.® INDICATES THAT THE MARK IS REGISTERED IN AT LEAST THE UNITED STATES. NO REPRESENTATION IS MADE WITH RESPECT TO THE SOURCE OF MANUFACTURE OF ANY PARTICULAR PART. © 2005, MIDWEST TRUCK & AUTO PARTS, INC.® ALL RIGHTS RESERVED.

INPUT SHAFTS

NUT OR SNAP RING	☞	SEE TABLE Z1
COVER	☞	SEE TABLE Z3
SEAL	☞	SEE TABLE Z2

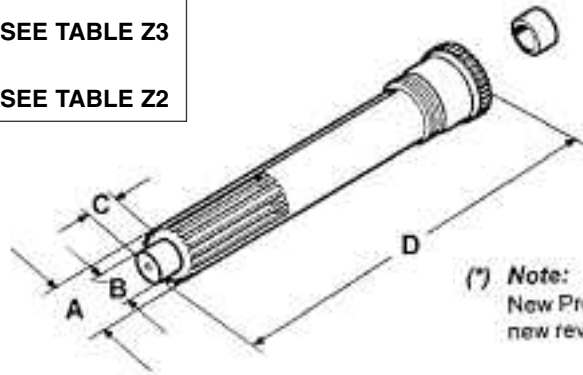

(*) Note:
New Production with
new revised spline.

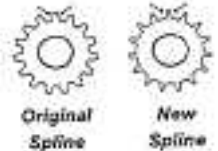

TABLE INPUT SHAFTS FOR 13 SPEEDS (Cont'd)

MODELS	INPUT KIT PART NO. Only Shaft	PART NO. W/BUSH	TYPE	A Inches	B Inches	C Inches	D Inches	NUT/ SR	COVER	SEAL
RT/RTO-11613	20532	S-1498	PUSH	1.75	1.18	0.81	11.94	F	L	---
RTOO-11613	20538	S-1504	PULL	1.75	1.18	0.81	11.94	F	M	---
	23566	S-1659*	PULL	2.00	1.18	0.81	11.94	F	N	---
	23567	S-1660	PUSH	2.00	1.18	0.81	11.94	F	O	---
<hr/>										
RT/RTO-14613	16465	S-1128	PULL	2.00	1.18	0.81	11.94	D	J	---
RT-14613B	16466	S-1129	PUSH	2.00	1.18	0.81	11.94	C	I	---
RTOO-14613	19716		PUSH	2.00	1.18	0.81	11.94	E	K	D
	18387	T20078	PUSH	1.75	0.98	1.23	12.92	C	U	A
	23566	S-1659*	PULL	2.00	1.18	0.81	11.94	F	N	---
	23567	S-1660	PUSH	2.00	1.18	0.81	11.94	F	O	---
<hr/>										
RTO-14813	23566	S-1659*	PULL	2.00	1.18	0.81	11.94	F	N	---
	23567	S-1660	PUSH	2.00	1.18	0.81	11.94	F	O	---
<hr/>										
RT/RTO-15613	18387	T20078	PUSH	1.75	0.98	1.23	12.92	C	U	A
RT-15613B	23566	S-1659*	PULL	2.00	1.18	0.81	11.94	F	N	---
<hr/>										
RTLO-14613	23566	S-1659*	PULL	2.00	1.18	0.81	11.94	F	N	---
	23567	S-1660	PUSH	2.00	1.18	0.81	11.94	F	O	---
<hr/>										
RTLO-12713	23566	S-1659*	PULL	2.00	1.18	0.81	11.94	F	N	---
	23567	S-1660	PUSH	2.00	1.18	0.81	11.94	F	O	---
<hr/>										
RTLO-14713	23566	S-1659*	PULL	2.00	1.18	0.81	11.94	F	N	---
	23567	S-1660	PUSH	2.00	1.18	0.81	11.94	F	O	---
<hr/>										
RTLO-16713	23566	S-1659*	PULL	2.00	1.18	0.81	11.94	F	N	---
	23567	S-1660	PUSH	2.00	1.18	0.81	11.94	F	O	---

PARTS LISTED IN THIS CATALOG ARE NOT NECESSARILY MANUFACTURED BY THE ORIGINAL EQUIPMENT MANUFACTURER AND ANY REFERENCE TO THE TRADEMARKS OR PART NUMBERS OF OTHERS ARE FOR CROSS REFERENCE INFORMATIONAL PURPOSES ONLY. THE TRADEMARKS OF OTHERS REFERRED TO HEREIN ARE OWNED BY THEIR RESPECTIVE COMPANIES AND ARE NOT AFFILIATED IN ANY WAY WITH MIDWEST TRUCK & AUTO PARTS, INC.® MOTIVE GEAR® AND WORLD AMERICAN® ARE THE REGISTERED TRADEMARKS OF MIDWEST TRUCK & AUTO PARTS, INC.® USE OF THE ® IN CONNECTION WITH A MARK OF MIDWEST TRUCK & AUTO PARTS, INC.® INDICATES THAT THE MARK IS REGISTERED IN AT LEAST THE UNITED STATES. NO REPRESENTATION IS MADE WITH RESPECT TO THE SOURCE OF MANUFACTURE OF ANY PARTICULAR PART. © 2005, MIDWEST TRUCK & AUTO PARTS, INC.® ALL RIGHTS RESERVED.

INPUT SHAFTS

NUT OR SNAP RING ☞ SEE TABLE Z1
 COVER ☞ SEE TABLE Z3
 SEAL ☞ SEE TABLE Z2

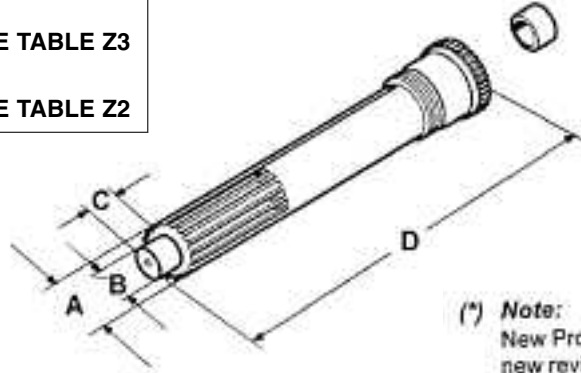

(*) Note:
 New Production with
 new revised spline.

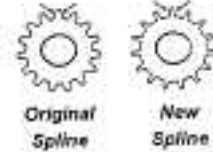

TABLE INPUT SHAFTS FOR 15 SPEEDS

MODELS	INPUT KIT PART NO. Only Shaft	PART NO. W/BUSH	TYPE	A Inches	B Inches	C Inches	D Inches	NUT/ SR	COVER	SEAL	
RT/RTO-915	15110	S-1133	PULL	2.00	1.18	0.81	12.12	D	J	---	
	15112	S-1134	PUSH	2.00	1.18	0.81	12.12	E	K	D	
	16983	S-1343	PULL	1.75	1.18	0.81	12.12	F	H	B	
	16984	S-1344	PULL	2.00	1.18	0.81	12.12	F	H	C	
	20530	S-1496	PUSH	1.75	1.18	0.81	12.12	F	L	---	
	20531	S-1497	PULL	1.75	1.18	0.81	12.12	F	M	---	
	23569	S-1661	PULL	2.00	1.18	0.81	12.12	F	N	---	
	23570	S-1662	PUSH	2.00	1.18	0.81	12.12	F	O	---	
RT/RTO-12515	16465	S-1128	PULL	2.00	1.18	0.81	11.94	D	J	---	
	16466	S-1129	PUSH	2.00	1.18	0.81	11.94	C	I	---	
	18837	S-1409	PULL	2.00	1.18	0.81	11.94	F	H	C	
	23566	S-1659	PULL	2.00	1.18	0.81	11.94	F	N	---	
	23567	S-1660	PUSH	2.00	1.18	0.81	11.94	F	O	---	
RT/RTO-11615	16465	S-1128	PULL	2.00	1.18	0.81	11.94	D	J	---	
	RTX-11615	16466	S-1129	PUSH	2.00	1.18	0.81	11.94	C	I	---
	RT/RTO-14615	18837	S-1409	PULL	2.00	1.18	0.81	11.94	F	H	C
	RTX-14615	19316	S-1406	PULL	1.75	1.18	0.81	11.94	D	G	---
		19714		PUSH	1.75	1.18	0.81	11.94	C	F	---
		19716		PUSH	2.00	1.18	0.81	11.94	E	K	D
		20532	S-1498	PUSH	1.75	1.18	0.81	11.94	F	L	---
		20538	S-1504	PULL	1.75	1.18	0.81	11.94	F	M	---
		23566	S-1659	PULL	2.00	1.18	0.81	11.94	F	N	---
		23567	S-1660	PUSH	2.00	1.18	0.81	11.94	F	O	---
RT/RTO-15615	18837	S-1409	PULL	2.00	1.18	0.81	11.94	F	H	C	
	RTX-15615	23566	S-1659	PULL	2.00	1.18	0.81	11.94	F	N	---
		23567	S-1660	PUSH	2.00	1.18	0.81	11.94	F	O	---
RT/RTO-11715	20532	S-1498	PUSH	1.75	1.18	0.81	11.94	F	L	---	
RTX-11715	20538	S-1504	PULL	1.75	1.18	0.81	11.94	F	M	---	

PARTS LISTED IN THIS CATALOG ARE NOT NECESSARILY MANUFACTURED BY THE ORIGINAL EQUIPMENT MANUFACTURER AND ANY REFERENCE TO THE TRADEMARKS OR PART NUMBERS OF OTHERS ARE FOR CROSS REFERENCE INFORMATIONAL PURPOSES ONLY. THE TRADEMARKS OF OTHERS REFERRED TO HEREIN ARE OWNED BY THEIR RESPECTIVE COMPANIES AND ARE NOT AFFILIATED IN ANY WAY WITH MIDWEST TRUCK & AUTO PARTS, INC.® MOTIVE GEAR® AND WORLD AMERICAN® ARE THE REGISTERED TRADEMARKS OF MIDWEST TRUCK & AUTO PARTS, INC.® USE OF THE ® IN CONNECTION WITH A MARK OF MIDWEST TRUCK & AUTO PARTS, INC.® INDICATES THAT THE MARK IS REGISTERED IN AT LEAST THE UNITED STATES. NO REPRESENTATION IS MADE WITH RESPECT TO THE SOURCE OF MANUFACTURE OF ANY PARTICULAR PART. © 2005, MIDWEST TRUCK & AUTO PARTS, INC.® ALL RIGHTS RESERVED.

INPUT SHAFTS

NUT OR SNAP RING		SEE TABLE Z1
COVER		SEE TABLE Z3
SEAL		SEE TABLE Z2

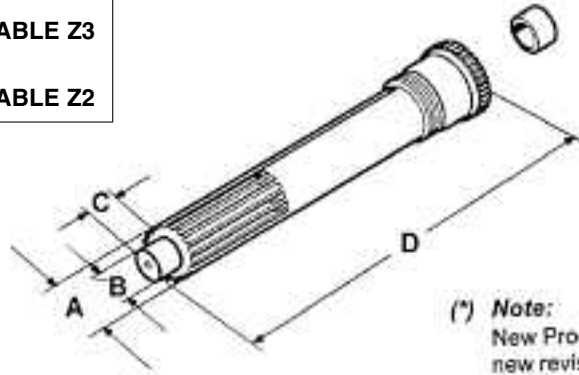

(*) Note:
New Production with
new revised spline.





TABLE INPUT SHAFTS FOR 15 SPEEDS

MODELS	INPUT KIT PART NO. Only Shaft	PART NO. W/BUSH	TYPE	A Inches	B Inches	C Inches	D Inches	NUT/ SR	COVER	SEAL
	23566	S-1659	PULL	2.00	1.18	0.81	11.94	F	N	---
	23567	S-1660	PUSH	2.00	1.18	0.81	11.94	F	O	---
<hr/>										
RT/RTO-14715	23566	S-1659	PULL	2.00	1.18	0.81	11.94	F	N	---
RTX-14715	23567	S-1660	PUSH	2.00	1.18	0.81	11.94	F	O	---
<hr/>										
RT/RTO-15715	23566	S-1659	PULL	2.00	1.18	0.81	11.94	F	N	---
RTX-15715	23567	S-1660	PUSH	2.00	1.18	0.81	11.94	F	O	---

PARTS LISTED IN THIS CATALOG ARE NOT NECESSARILY MANUFACTURED BY THE ORIGINAL EQUIPMENT MANUFACTURER AND ANY REFERENCE TO THE TRADEMARKS OR PART NUMBERS OF OTHERS ARE FOR CROSS REFERENCE INFORMATIONAL PURPOSES ONLY. THE TRADEMARKS OF OTHERS REFERRED TO HEREIN ARE OWNED BY THEIR RESPECTIVE COMPANIES AND ARE NOT AFFILIATED IN ANY WAY WITH MIDWEST TRUCK & AUTO PARTS, INC.® MOTIVE GEAR® AND WORLD AMERICAN® ARE THE REGISTERED TRADEMARKS OF MIDWEST TRUCK & AUTO PARTS, INC.® USE OF THE ® IN CONNECTION WITH A MARK OF MIDWEST TRUCK & AUTO PARTS, INC.® INDICATES THAT THE MARK IS REGISTERED IN AT LEAST THE UNITED STATES. NO REPRESENTATION IS MADE WITH RESPECT TO THE SOURCE OF MANUFACTURE OF ANY PARTICULAR PART. © 2005, MIDWEST TRUCK & AUTO PARTS, INC.® ALL RIGHTS RESERVED.

INPUT SHAFTS

NUT OR SNAP RING		SEE TABLE Z1
COVER		SEE TABLE Z3
SEAL		SEE TABLE Z2

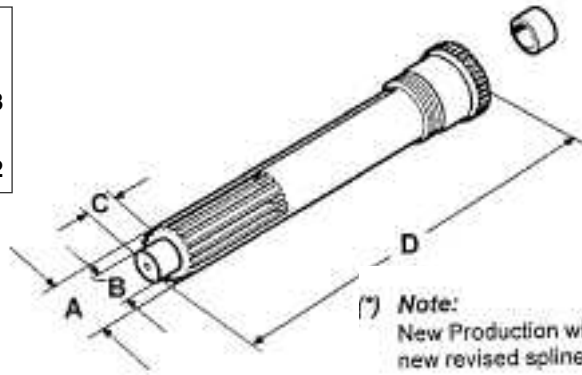

(*) Note:
New Production with
new revised spline.

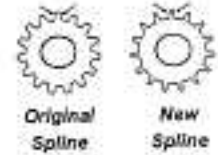

TABLE INPUT SHAFTS FOR 18 SPEEDS

MODELS	INPUT KIT PART NO. Only Shaft	PART NO. W/BUSH	TYPE	A Inches	B Inches	C Inches	D Inches	NUT/SR	COVER	SEAL
RTO-15618	23566	S-1659*	PULL	2.00	1.18	0.81	11.94	F	N	---
	23567	S-1660	PUSH	2.00	1.18	0.81	11.94	F	O	---
RTLO-14618	23566	S-1659*	PULL	2.00	1.18	0.81	11.94	F	N	---
	23567	S-1660	PUSH	2.00	1.18	0.81	11.94	F	O	---
RTLO-16618	23566	S-1659*	PULL	2.00	1.18	0.81	11.94	F	N	---
	23567	S-1660	PUSH	2.00	1.18	0.81	11.94	F	O	---
RTLO-14718	23566	S-1659*	PULL	2.00	1.18	0.81	11.94	F	N	---
	23567	S-1660	PUSH	2.00	1.18	0.81	11.94	F	O	---
RTLO-16718	23566	S-1659*	PULL	2.00	1.18	0.81	11.94	F	N	---
	23567	S-1660	PUSH	2.00	1.18	0.81	11.94	F	O	---
RTLO-18718	4302661	S-2265	PULL	2.00				F	N	---
RTLO-14918	23566	S-1659*	PULL	2.00	1.18	0.81	11.94	F	N	---
	23567	S-1660	PUSH	2.00	1.18	0.81	11.94	F	O	---
RTLO-16918	23566	S-1659*	PULL	2.00	1.18	0.81	11.94	F	N	---
	23567	S-1660	PUSH	2.00	1.18	0.81	11.94	F	O	---
RTLO-18918	23566	S-1659*	PULL	2.00	1.18	0.81	11.94	F	N	---
	23567	S-1660	PUSH	2.00	1.18	0.81	11.94	F	O	---
RTLO-20918	23566	S-1659*	PULL	2.00	1.18	0.81	11.94	F	N	---
RTLO-20918-TX	23567	S-1660	PUSH	2.00	1.18	0.81	11.94	F	O	---

PARTS LISTED IN THIS CATALOG ARE NOT NECESSARILY MANUFACTURED BY THE ORIGINAL EQUIPMENT MANUFACTURER AND ANY REFERENCE TO THE TRADEMARKS OR PART NUMBERS OF OTHERS ARE FOR CROSS REFERENCE INFORMATION PURPOSES ONLY. THE TRADEMARKS OF OTHERS REFERRED TO HEREIN ARE OWNED BY THEIR RESPECTIVE COMPANIES AND ARE NOT AFFILIATED IN ANY WAY WITH MIDWEST TRUCK & AUTO PARTS, INC.® MOTIVE GEAR® AND WORLD AMERICAN® ARE THE REGISTERED TRADEMARKS OF MIDWEST TRUCK & AUTO PARTS, INC.® USE OF THE ® IN CONNECTION WITH A MARK OF MIDWEST TRUCK & AUTO PARTS, INC.® INDICATES THAT THE MARK IS REGISTERED IN AT LEAST THE UNITED STATES. NO REPRESENTATION IS MADE WITH RESPECT TO THE SOURCE OF MANUFACTURE OF ANY PARTICULAR PART. © 2005, MIDWEST TRUCK & AUTO PARTS, INC.® ALL RIGHTS RESERVED.