

# FEATURES & BENEFITS OF OUR PTO'S

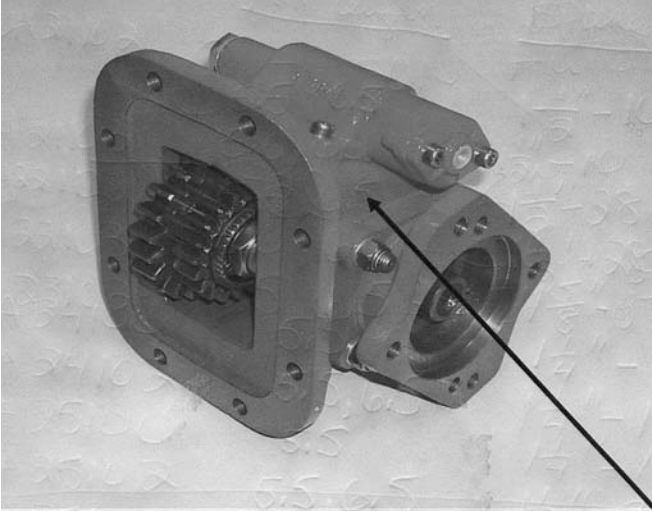

Our **Power Take Off Housing** is made from **CAST IRON**. The competition offers an aluminum construction. Cast iron is the material of choice for heavy duty applications.

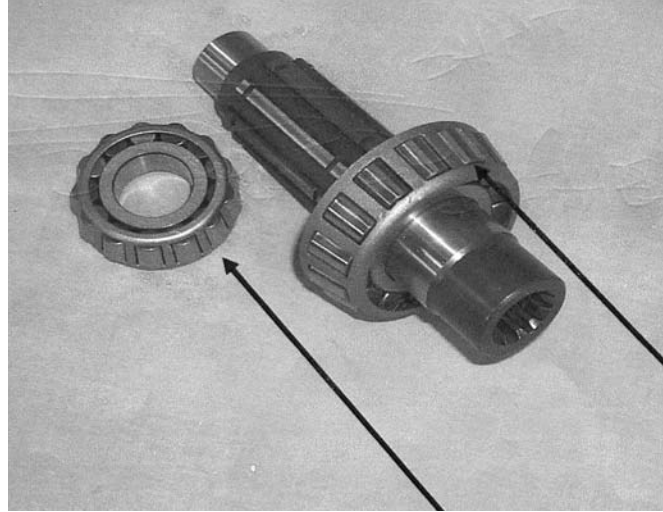

We use **large tapered bearings** on both ends of the output shaft, affording the user extended life and trouble-free service of our Power Take Off.

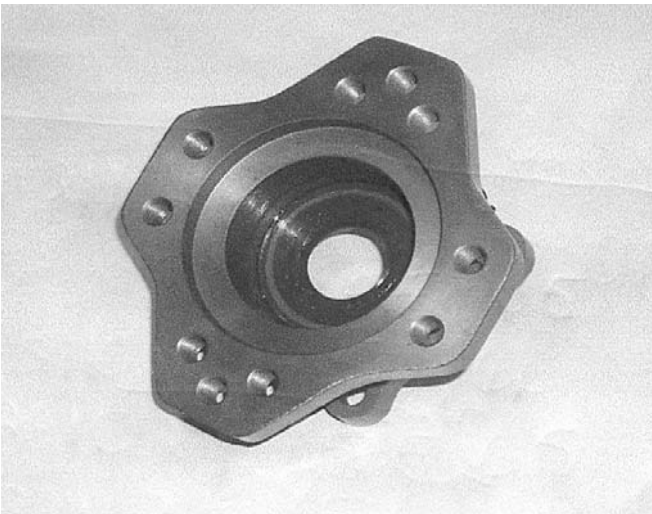

Our **CAST IRON ROTATABLE FLANGE WITH DOUBLE LIP SEAL**, gives you a solid, versatile connection between the pump and PTO. Others offer only aluminum.

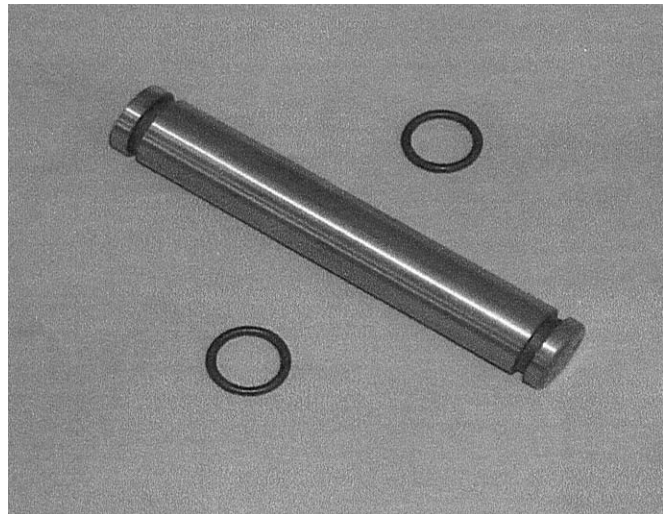

The large diameter idler pin assembly utilizes internally mounted o-rings, away from all of the road grime. Our **idler pin is held in place by a snap-ring**; no set screws to vibrate loose.

PARTS LISTED IN THIS CATALOG ARE NOT NECESSARILY MANUFACTURED BY THE ORIGINAL EQUIPMENT MANUFACTURER AND ANY REFERENCE TO THE TRADEMARKS OR PART NUMBERS OF OTHERS ARE FOR CROSS REFERENCE INFORMATION-AL PURPOSES ONLY. THE TRADEMARKS OF OTHERS REFERRED TO HEREIN ARE OWNED BY THEIR RESPECTIVE COMPANIES AND ARE NOT AFFILIATED IN ANY WAY WITH MIDWEST TRUCK & AUTO PARTS, INC.™ MOTIVE GEAR®, MOTIVE GEAR AND DESIGN®, MOTIVE GEAR PERFORMANCE®, AND MOTIVE GEAR PERFORMANCE AND DESIGN® ARE THE REGISTERED TRADEMARKS OF MIDWEST TRUCK & AUTO PARTS, INC.™ USE OF THE ® IN CONNECTION WITH A MARK OF MIDWEST TRUCK & AUTO PARTS, INC.™ INDICATES THAT THE MARK IS REGISTERED IN AT LEAST THE UNITED STATES. WORLD AMERICAN™ AND WORLD AMERICAN AND DESIGN™ ARE TRADEMARKS OF MIDWEST TRUCK & AUTO PARTS, INC.™ NO REPRESENTATION IS MADE WITH RESPECT TO THE SOURCE OF MANUFACTURE OF ANY PARTICULAR PART. © 2005, MIDWEST TRUCK & AUTO PARTS, INC.™ ALL RIGHTS RESERVED.

# FEATURES & BENEFITS OF OUR PTO'S

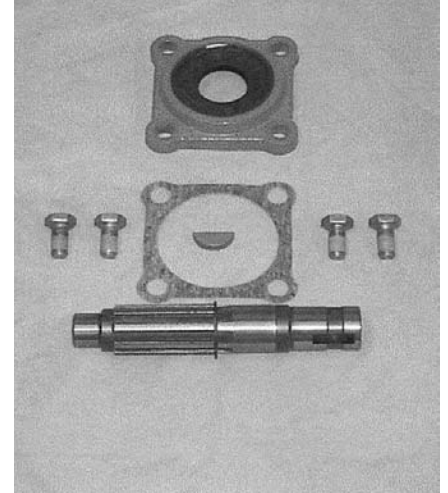
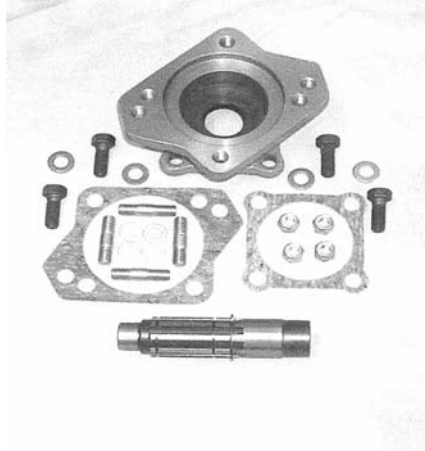
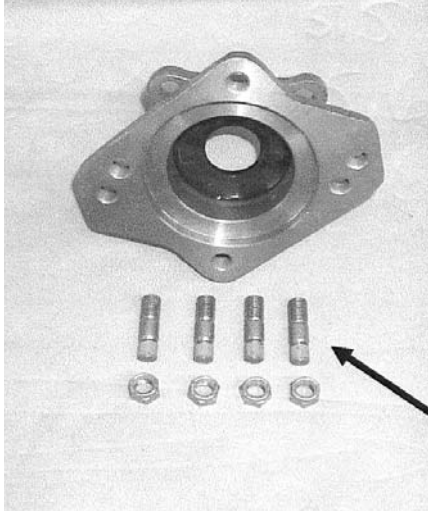

The **12mm (approximately 1/2") VIBRA-TITE™ coated assembly studs, NY-LOCK™ Nuts and gaskets** between all mating parts maintain the integrity of our assemblies during the constant vibration caused by the road and connections between mechanical components.  
The competition uses NO gaskets and much smaller assembly bolts.

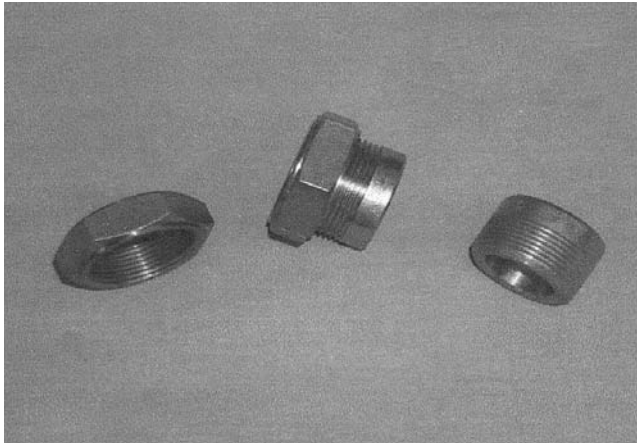

The **Expandable Adjusting Nut** for adjusting input gear end-play is a time and money saver. It also provides a slight preload on bearings for longer bearing life. No more fighting shims to get the proper endplay adjustment.

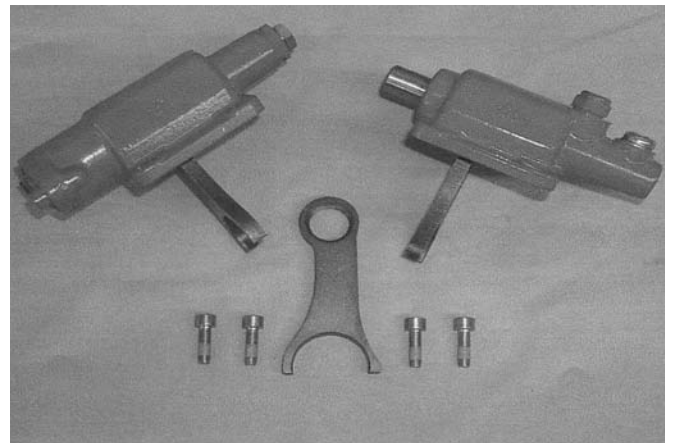

Our **steel shifting fork** offers the strength needed under the toughest of shifting conditions.

PARTS LISTED IN THIS CATALOG ARE NOT NECESSARILY MANUFACTURED BY THE ORIGINAL EQUIPMENT MANUFACTURER AND ANY REFERENCE TO THE TRADEMARKS OR PART NUMBERS OF OTHERS ARE FOR CROSS REFERENCE INFORMATIONAL PURPOSES ONLY. THE TRADEMARKS OF OTHERS REFERRED TO HEREIN ARE OWNED BY THEIR RESPECTIVE COMPANIES AND ARE NOT AFFILIATED IN ANY WAY WITH MIDWEST TRUCK & AUTO PARTS, INC.™ MOTIVE GEAR®, MOTIVE GEAR AND DESIGN®, MOTIVE GEAR PERFORMANCE®, AND MOTIVE GEAR PERFORMANCE AND DESIGN® ARE THE REGISTERED TRADEMARKS OF MIDWEST TRUCK & AUTO PARTS, INC.™ USE OF THE "®" IN CONNECTION WITH A MARK OF MIDWEST TRUCK & AUTO PARTS, INC.™ INDICATES THAT THE MARK IS REGISTERED IN AT LEAST THE UNITED STATES. WORLD AMERICAN™ AND WORLD AMERICAN AND DESIGN™ ARE TRADEMARKS OF MIDWEST TRUCK & AUTO PARTS, INC.™ NO REPRESENTATION IS MADE WITH RESPECT TO THE SOURCE OF MANUFACTURE OF ANY PARTICULAR PART. © 2005, MIDWEST TRUCK & AUTO PARTS, INC.™ ALL RIGHTS RESERVED.